

4 x 2.5 x 0.6mm SMD

WI-FI APPLICATIONS

FEATURES

- **Miniature package: 4.0 x 2.5 x 0.6mm**
- **Gold-plated ceramic base with metal seam-welded package**
- **Very low ageing**
- **Optimized for Wi-Fi applications**
- **High shock and vibration resistance**



DESCRIPTION

X42 crystals are micro-miniature surface-mount mount crystals. The crystals have a gold plated ceramic base with a seam welded metal lid providing a stable crystal with very low ageing. The rugged construction ensures that this crystal has high shock and vibration resistance. The crystal has been optimized for Wi-Fi applications: Bluetooth/ Bluetooth Low Energy (BLE), Bluetooth Smart, Zigbee, ISM, Wi-Fi / WLAN, LPWAN and others.

SPECIFICATION

Standard Frequencies*:	16.0, 19.2, 20.0, 24.0, 25.0, 26.0, 27.120, 30.0, 32.0, 37.40, 38.40, 40.0, 48.0, 52.0MHz
Operating Mode:	AT-Cut Fundamental:
Calibration Tolerance at 25°C:	±10ppm
Frequency stability	
-20° to +70°C	±10ppm
-40° to +85°C	±15ppm
-40° to +105°C	±30ppm
Storage Temperature:	-50°~+105°C
Equivalent Series Resistance:	See table
Shunt Capacitance (C0):	2pF to 4pF typical, 5pF maximum
Load Capacitance (CL):	Series or from 10pF to 32pF (Customer specified CL)
Ageing:	< ±ppm per first year at +25°C
Drive level:	100 µW maximum
Reflow Soldering:	10s maximum at 260°C twice or 180s at 230°C, once.
Packaging:	12mm EIA tape and reel

OUTLINE & DIMENSIONS

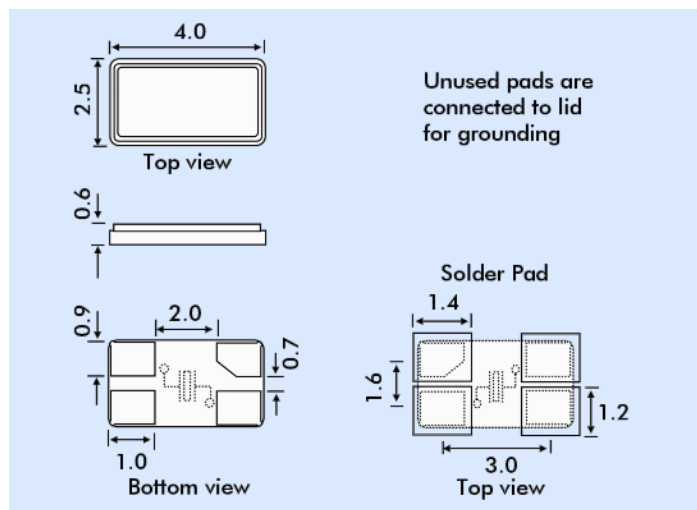

* Note: These parts may be supplied with the chamfered pad in different positions. However, the crystal connection is always as shown above.

*Note: Custom frequencies are available.

EQUIVALENT SERIES RESISTANCE (ESR)

Frequency Range MHz	Crystal Cut/ Mode	ESR Ω Max.
12.0 ~ 14.9	AT Fund.	80
15.0 ~ 29.9	AT Fund.	50
30.0 ~ 54.0	AT Fund.	40

ENVIRONMENTAL PERFORMANCE

RoHS Status:	Compliant
Storage Temperature Range:	-55° to +105°C
Humidity:	85% RH, 85°C for 48 hours
Hermetic Seal:	Leak rate 2x10 ⁻⁸ ATM -cm ³ /s max.
Solderability:	MIL-STD-202F Method 208E
Reflow:	260°C for 10 sec (see diagram)
Vibration:	MIL-STD-202F Method 204, 35±5 mins, 50 to 2000Hz
Shock:	MIL-STD-202F Method 213B, test Condition E, 50g 11ms.

PART NUMBER GENERATION

Part numbers for X42-W crystals are generated as follows:

