

OUTLINE & DIMENSIONS

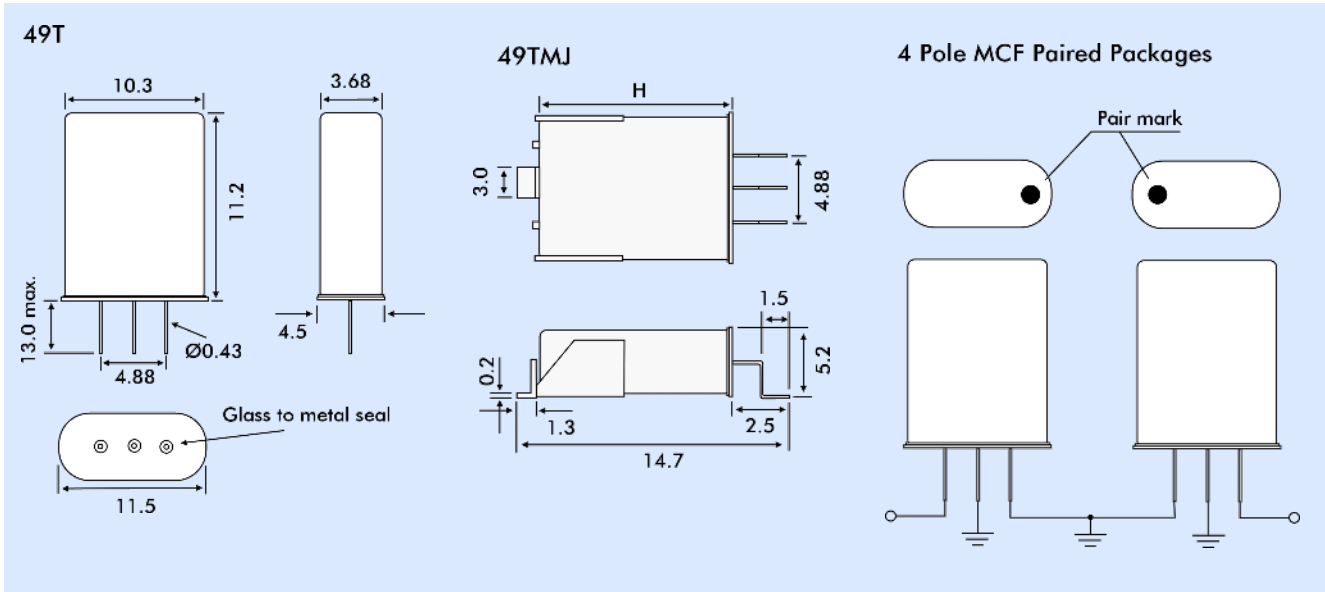

SPECIFICATIONS

Channel Spacing (kHz)	Model	No. of Poles	Pass Bandwidth		Stop Bandwidth		Ripple dB max.	Insertion Loss dB max.	Guaranteed Attenuation		Term. Imp. Ω/μF	Package	
			dB	kHz	dB	kHz			dB	kHz		Tandem Set	One Package
12.5	10M7.5A	2	3	±3.75	20	±18	0.5	1.5	35	±300~±1000	1.8k//5.0		49T
	10M7.5B	4	3	±3.75	40	±14	1.0	2.5	65	±300~±1000	1.8k//4.5	49T (pair)	
	10M7.5C	6	3	±3.75	45	±8.75	2.0	3.5	65	±12.5~±300	1.8k//3.5	49T (3 pcs)	L1
	10M7.5D	8	3	±3.75	65	±8.75	2.0	4.0	90	±12.5~±300	1.8k//3.5	49T (4 pcs)	L2
20.0	10M12A	2	3	±6.0	18	±25	0.5	2.0	35	±300~±1000	2.5k//2.5		49T
	10M12B	4	3	±6.0	40	±20	1.0	2.5	65	±300~±1000	2.5k//1.5	49T (pair)	
	10M12C	6	3	±6.0	45	±15	1.0	4.0	65	±20~±300	2.5k//1.5	49T (3 pcs)	L1
	10M12D	8	3	±6.0	65	±15	2.0	2.0	90	±20~±300	2.5k//1.5	49T (4 pcs)	L2
25.0	10M15A	2	3	±7.5	18	±25	0.5	1.5	35	±300~±1000	3.0k//2.0		49T
	10M15B	4	3	±7.5	40	±25	1.0	2.5	55	±300~±1000	3.0k//1.5	49T (pair)	
	10M15C	6	3	±7.5	45	±18	2.0	3.0	65	±25~±300	3.3k//1.5	49T (3 pcs)	L1
	10M15D	8	3	±7.5	65	±18	2.0	4.0	90	±25~±300	3.3k//1.5	49T (4 pcs)	L2
50.0	10M30A	2	3	±15	15	±50	0.5	1.5	30	±300~±1000	5.0k//0		49T
	10M30B	4	3	±15	30	±40	1.0	2.5	30	±300~±1000	5.5k//1.0	49T (pair)	
	10M30C	6	3	±15	60	±45	2.0	3.0	65	±45~±300	5.5k//1.0	49T (3 pcs)	L1
	10M30D	8	3	±15	90	±30	2.0	3.5	90	±50~±300	5.5k//1.0	49T (4 pcs)	L2

PART NUMBER FORMAT

Example: **10M7.5A**

Centre Frequency Code
10M = 10.7MHz

Pass Bandwidth (at 3dB min.)
7.5 = ±3.75kHz
12 = ±6.0kHz
15 = ±7.5kHz
30 = ±15kHz

Number of Poles
A = 2 poles
B = 4 poles
C = 6 poles
D = 8 poles

L-1 and L-2 Packages

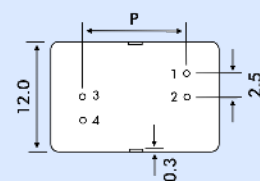
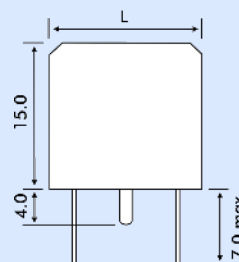

Pin 1 Output
Pin 2 Ground
Pin 3 Ground
Pin 4 Input

	L	P
L-1	15.0	9.0
L-2	18.5	13.4

PACKAGE OUTLINE & DIMENSIONS

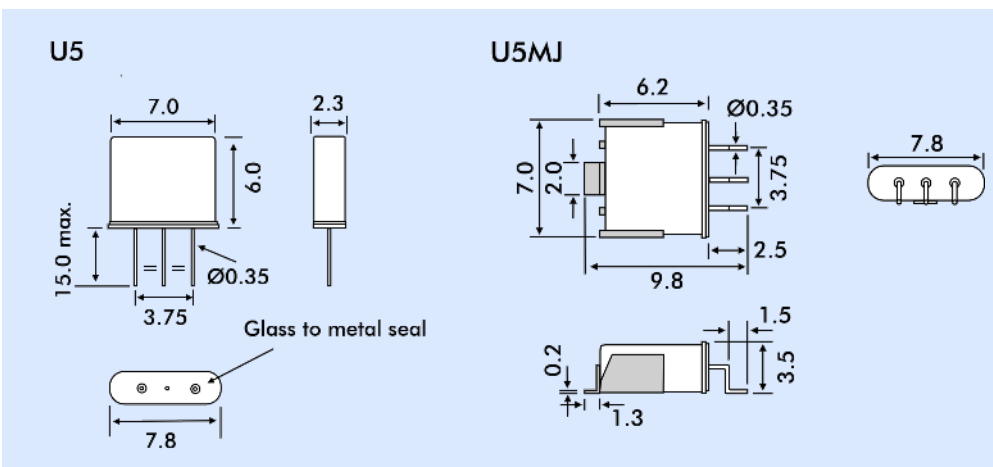
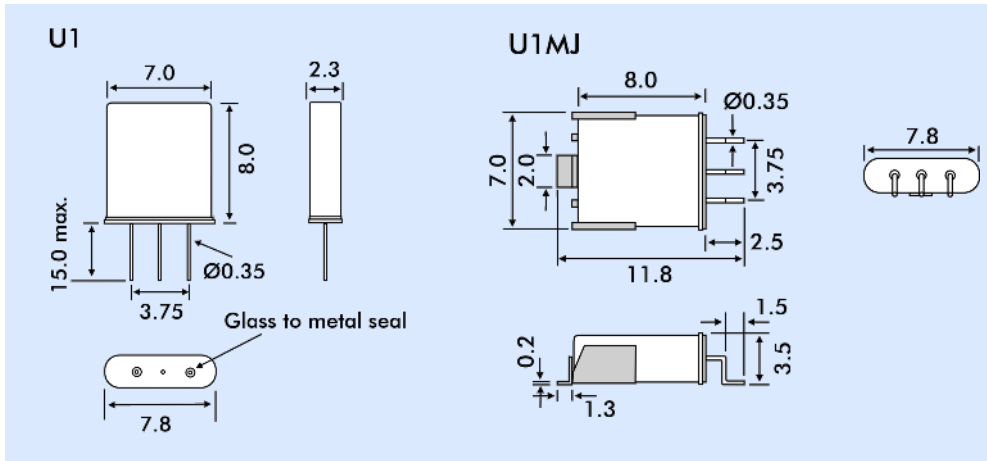

SPECIFICATIONS

Channel Spacing (kHz)	Model	No. of Poles	Pass Bandwidth		Stop Bandwidth		Ripple dB max.	Insertion Loss dB max.	Guaranteed Attenuation		Term. Imp. Ω//pF	Package	
			dB	kHz	dB	kHz			dB	kHz		Tandem Set	One Package
12.5	45M7.5A	2	3	±3.75	10	±12.5	1.0	2.0	65	±300~±1000	200//4.0	U5	U1
	45M7.5B	4	3	±3.75	30	±12.5	1.0	4.0	80	±300~±1000	350//6.5	U5 (pair)	U1 (pair)
25.0	45M15A	2	3	±7.5	15	±25	1.0	2.0	35	±300~±1000	650//3.0	U5	U1
	45M15B	4	3	±7.5	30	±25	1.0	3.0	80	±300~±1000	650//3.0	U5 (pair)	U1 (pair)
50.0	45M30A	2	3	±15	15	±60	1.5	2.5	35	±300~±1000	1.2k//0	U5	U1
	45M30B	4	3	±15	30	±50	1.0	3.0	80	±300~±1000	1.2k//0.7	U5 (pair)	U1 (pair)

PART NUMBER FORMAT

Example: 21M7.5A

Centre Frequency Code

21M = 21.4MHz
45M = 45.0MHz

Pass Bandwidth (at 3dB min.)

7.5 = ±3.75kHz
12 = ±6.0kHz
15 = ±7.5kHz
30 = ±15kHz

Number of Poles

A = 2 poles
B = 4 poles
C = 6 poles
D = 8 poles

L-1 and L-2 Packages

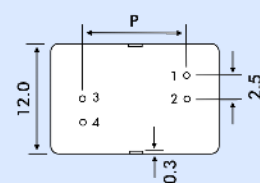
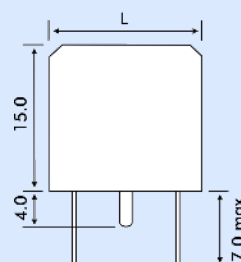

Pin 1 Output
Pin 2 Ground
Pin 3 Ground
Pin 4 Input

	L	P
L-1	15.0	9.0
L-2	18.5	13.4



SPECIFICATIONS

Channel Spacing (kHz)	Model	No. of Poles	Pass Bandwidth		Stop Bandwidth		Ripple dB max.	Insertion Loss dB max.	Guaranteed Attenuation		Term. Imp. Ω//pF	Package	
			dB	kHz	dB	kHz			dB	kHz		Tandem Set	One Package
12.5	21M7.5A	2	3	±3.75	20	±18	0.5	1.5	35	±300~±1000	850//6.0		49T
	21M7.5B	4	3	±3.75	40	±15	1.0	2.5	65	±300~±1000	850//5.0	49T (pair)	
	21M7.5C	6	3	±3.75	45	±8.75	2.0	3.5	65	±12.5~±300	850//5.0	49T (3 pcs)	L1
	21M7.5D	8	3	±3.75	65	±8.75	2.0	4.0	90	±12.5~±300	850//5.0	49T (4 pcs)	L2
20.0	21M12A	2	3	±6.0	20	±25	0.5	1.5	35	±300~±1000	1.2k//3.0		49T
	21M12B	4	3	±6.0	40	±20	1.0	2.5	65	±300~±1000	1.2k//2.5	49T (pair)	
	21M12C	6	3	±6.0	45	±15	2.0	3.0	65	±20~±300	1.2k//2.5	49T (3 pcs)	L1
	21M12D	8	3	±6.0	65	±15	2.0	4.0	90	±20~±300	1.2k//2.5	49T (4 pcs)	L2
25.0	21M15A	2	3	±7.5	18	±25	0.5	1.5	35	±300~±1000	1.5k//2.0		49T
	21M15B	4	3	±7.5	40	±25	1.0	2.5	55	±300~±1000	1.5k//2.0	49T (pair)	
	21M15C	6	3	±7.5	45	±18	2.0	3.0	65	±25~±300	1.5k//2.0	49T (3 pcs)	L1
	21M15D	8	3	±7.5	65	±18	2.0	4.0	90	±25~±300	1.5k//2.0	49T (4 pcs)	L2
50.0	21M30A	2	3	±15	15	±45	0.5	1.5	30	±300~±1000	1.5k//1.0		49T
	21M30B	4	3	±15	40	±50	1.0	2.5	30	±300~±1000	2.2k//0.5	49T (pair)	
	21M30C	6	3	±15	45	±35	2.0	3.0	65	±45~±300	2.2k//0.5	49T (3 pcs)	L1
	21M30D	8	3	±15	65	±35	2.0	4.0	90	±50~±300	2.2k//0.5	49T (4pcs)	L2

SPECIFICATIONS

Channel Spacing (kHz)	Model	No. of Poles	Pass Bandwidth		Stop Bandwidth		Ripple dB max.	Insertion Loss dB max.	Guaranteed Attenuation		Term. Imp. Ω//pF	Package	
			dB	kHz	dB	kHz			dB	kHz		Tandem Set	One Package
12.5	45M7.5A	2	3	±3.75	10	±12.5	1.0	2.0	65	±300~±1000	200//4.0	U5	U1
	45M7.5B	4	3	±3.75	30	±12.5	1.0	4.0	80	±300~±1000	350//6.5	U5 (pair)	U1 (pair)
25.0	45M15A	2	3	±7.5	15	±25	1.0	2.0	35	±300~±1000	650//3.0	U5	U1
	45M15B	4	3	±7.5	30	±25	1.0	3.0	80	±300~±1000	650//3.0	U5 (pair)	U1 (pair)
50.0	45M30A	2	3	±15	15	±60	1.5	2.5	35	±300~±1000	1.2k//0	U5	U1
	45M30B	4	3	±15	30	±50	1.0	3.0	80	±300~±1000	1.2k//0.7	U5 (pair)	U1 (pair)

PART NUMBER FORMAT

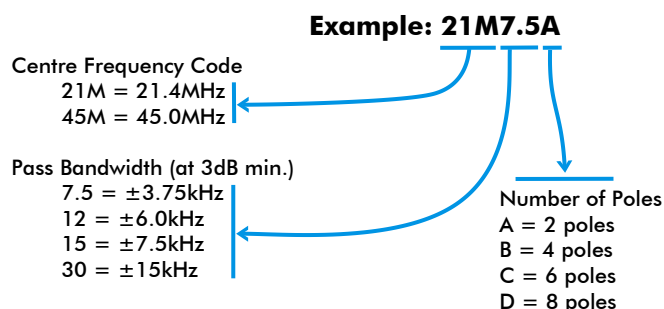

L-1 and L-2 Packages

