

- Frequency range 200.1MHz to 800MHz
- LVCMOS Output
- Supply Voltage 3.3 VDC
- High Q fundamental mode crystal
- Low jitter multiplier circuit



DESCRIPTION

GW42 VCXOs, are packaged in an industry-standard, 4 pad, 11.4mm x 9.6mm x 2.5mm SMD package. GW42 VCXOs incorporate a high Q fundamental crystal and a low jitter multiplier circuit.

SPECIFICATION

Frequency Range:	200.1MHz to 800.0MHz
Supply Voltage:	3.3 VDC \pm 5%
Output Logic:	LVCMOS
Integrated Phase Jitter:	2.6ps typical, 4.0ps maximum (for 155.250MHz)
Period Jitter RMS:	4.3ps typical (for 155.250MHz)
Period Jitter Peak to peak:	27.0ps typical (for 155.250MHz)
Phase Noise:	See table below
Initial Frequency Accuracy:	Tune to the nominal frequency with $V_c = 1.65 \pm 0.2VDC$
Output Voltage HIGH (1):	90% Vdd minimum
Output Voltage LOW (0):	10% Vdd maximum
Pulling Range:	From $\pm 30ppm$ to $\pm 150ppm$
Temperature Stability:	See table
Output Load:	15pF
Start-up Time:	10ms maximum, 5ms typical
Duty Cycle:	50% \pm 5% measured at 50% Vdd
Rise/Fall Times:	1.2ns typical (15pF load)
Current Consumption	
<96MHz:	30mA maximum (15pF load)
>96MHz:	40mA maximum (15pF load)
Linearity:	10% maximum, 6% typical
Modulation Bandwidth:	25kHz minimum
Input Impedance:	2 M Ω minimum
Slope Polarity: (Transfer function)	Monotonic and Positive. (An increase of control voltage always increases output frequency.)
Storage Temperature:	-50° to +100°C
Ageing:	$\pm 5ppm$ per year maximum
Enable/Disable (Tristate):	Not available (4 pad package)
RoHS Status:	Fully compliant

OUTLINE & DIMENSIONS

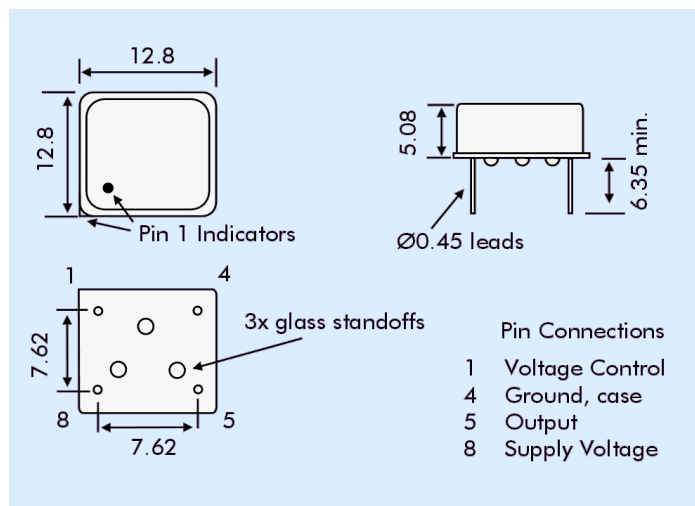

PHASE NOISE

10Hz	-65dBc/Hz
100Hz	-95dBc/Hz
1kHz	-120dBc/Hz
10kHz	-125dBc/Hz
100kHz	-121dBc/Hz
1MHz	-120dBc/Hz
10MHz	-140dBc/Hz

FREQUENCY STABILITY

Stability Code	Stability $\pm ppm$	Temp. Range
A	25	0°~+70°C
B	50	0°~+70°C
C	100	0°~+70°C
D	25	-40°~+85°C
E	50	-40°~+85°C
F	100	-40°~+85°C

If non-standard frequency stability is required
Use 'I' followed by stability, i.e. I20 for $\pm 20ppm$

PART NUMBERING

