

8 pin Dual-in-Line

50.01MHz ~ 640.0MHz

- Frequency range 50.01MHz to 640MHz
- LVCMOS Output
- Supply Voltage 3.3 VDC
- High Q fundamental crystal
- Ultra low jitter less than 1ps



DESCRIPTION

GF8 VCXOs, are packaged in an industry-standard, 8 pin Dual in Line package. GF8 VCXOs provide excellent phase jitter performance, less than 1ps.

SPECIFICATION

Frequency Range	50.01MHz to 640.0MHz
Supply Voltage:	3.3 VDC $\pm 5\%$
Output Logic:	LVCMOS
Integrated Phase Jitter:	0.4ps typical, 0.5ps maximum (for 156.250MHz)
Period Jitter RMS:	3.0ps typical (for 156.250MHz)
Period Jitter Peak to peak:	20ps typical (for 156.250MHz)
Phase Noise:	See table below
Initial Frequency Accuracy:	Tune to the nominal frequency with $V_c = 1.65 \pm 0.2VDC$
Output Voltage HIGH (1):	90% Vdd minimum
Output Voltage LOW (0):	10% Vdd maximum
Frequency Deviation Range:	$\pm 80ppm$ minimum
Temperature Stability:	See table
Output Load:	15pF
Start-up Time:	10ms maximum, 5ms typical
Duty Cycle:	50% $\pm 5\%$ measured at 50% Vdd
Rise/Fall Times:	0.7ns typical (15pF load)
Current Consumption	
<100MHz:	30mA maximum (15pF load)
>100MHz:	40mA maximum (15pF load)
Linearity:	10% maximum, 6% typical
Modulation Bandwidth:	25kHz minimum
Input Impedance:	60k Ω minimum
Slope Polarity:	Monotonic and Positive. (An increase of control voltage increases output frequency.)
Storage Temperature:	-50° to +100°C
Ageing:	$\pm 3ppm$ per year first year $\pm 2ppm$ per year thereafter
Enable/Disable (Tristate):	Not available (4 pad package)
RoHS Status:	Fully compliant

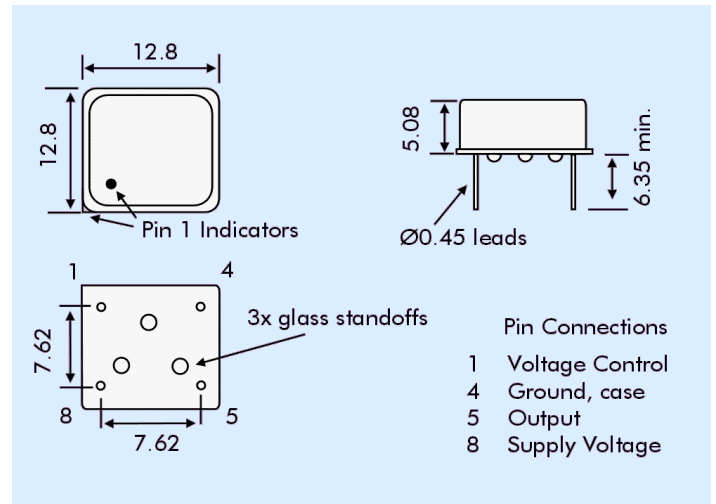

PHASE NOISE

Offset	Frequency 155.25MHz
10Hz	-62dBc/Hz
100Hz	-92dBc/Hz
1kHz	-120dBc/Hz
10kHz	-132dBc/Hz
100kHz	-128dBc/Hz
1MHz	-140dBc/Hz
10MHz	-150dBc/Hz

FREQUENCY STABILITY

Stability Code	Stability $\pm ppm$	Temp. Range
A	25	0°~+70°C
B	50	0°~+70°C
C	100	0°~+70°C
D	25	-40°~+85°C
E	50	-40°~+85°C
F	100	-40°~+85°C

If non-standard frequency stability is required
Use 'I' followed by stability, i.e. I20 for $\pm 20ppm$

PART NUMBERING

