

## 7 x 5 x 1.4mm SMD - Group 'N'

- Provides from 8dB to 15dB reduction in system EMI
- 'Drop-in' replacement for standard clocks
- Choice of modulation rate and spread
- Miniature package: 7.0 mm x 5.0 mm x 1.4mm
- N Group parts provide a low cost EMI reduction solution

Page 1 of 3

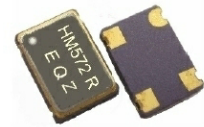

In electrical systems the principal cause of electro-magnetic interference (EMI) is the system clock oscillator. Traditional methods of 'patching-up' systems with too high a level of EMI is to use ferrite beads, filters, ground planes, metal shielding and similar costly methods, However, the most efficient and economic method to reduce EMI is to reduce it at source: replace the system clock oscillator with a low EMI clock oscillator.

Compared with conventional clock oscillators, Spread Spectrum (Dithered) Oscillators can reduce EMI by as much as 16dB. The part is a 'drop-in' replacement for a standard clock oscillator hence there is no requirement to re-design existing PCBs.

### APPLICATIONS

- Printers, Multiple Function Printers (MPCs)
- Digital Copiers; PDAs
- Networking: LAN/WAN; Routers
- Storage Systems (CD-ROM, VCD, DVD, HDD)
- Scanners; Modems; Projectors
- Embedded Systems
- Musical Instruments
- Automotive: GPS car navigation systems
- LCD PC Monitors; LSD TVs
- ADSL; PCMCIA
- Still Digital Cameras (SDCs)
- Medical devices

### DESCRIPTION

EQHM572 series low EMI oscillators can reduce system EMI from 8dB to 16dB. The oscillators are a 'drop-in' replacement for standard oscillators. EMI reduction is achieved by the use of Spread Spectrum Technology whereby the mode energy is spread over a wider bandwidth. The modulation carrier frequency, operating in the kHz region, makes the process transparent to the oscillator frequency. There is a choice of modulation rates and spread to suit application requirements.

### SPREAD SPECTRUM TECHNOLOGY

Unlike a conventional clock oscillator, in a Spread Spectrum Clock Oscillator the mode energy is spread over a wider bandwidth. This is achieved by the frequency modulation technique. The controlled modulation process may be applied to the 'down' side of the nominal frequency (known as **DOWN SPREAD**), or spread equally either side of nominal (**CENTRE SPREAD**). Down Spread is preferred if over-clocking would cause a problem to the system.

### MODULATION TYPES - EXAMPLES

Output amplitude (dB) vs. frequency span (MHz)

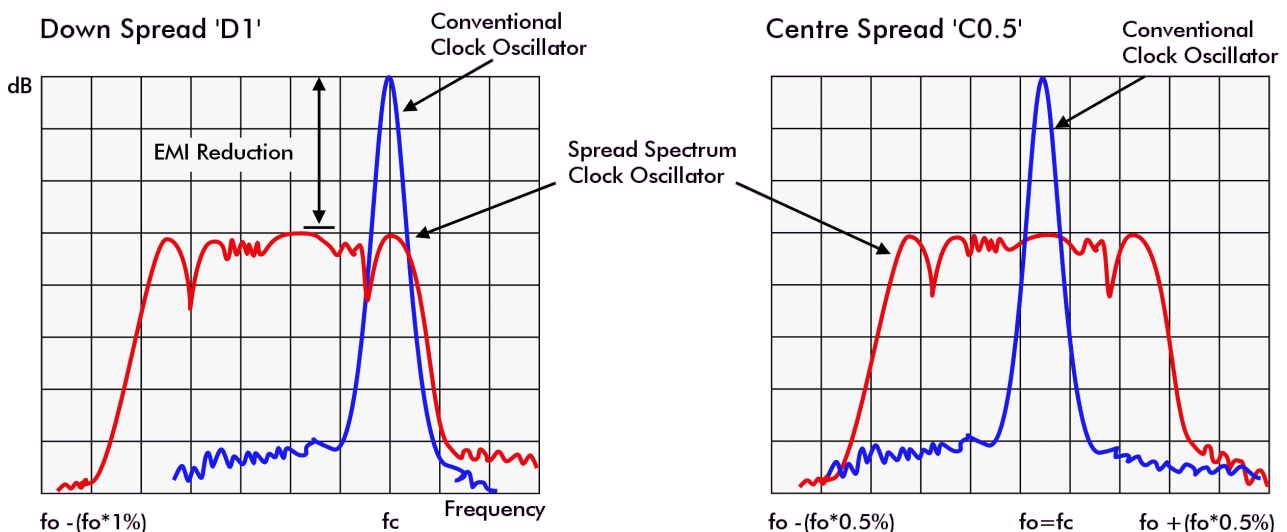

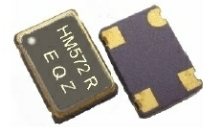

### SPECIFICATION

Model No:	3EQHM572 (Group 'N')
Frequency Range:	8.0MHz to 128.0MHz
Spread Types:	Down or Centre spread
Spread Magnitude:	See table 1 below. (Tolerance = $\pm 5\%$ of total &)
EMI Reduction:	8~15dB reduction typical. Fundamental and higher order harmonics.
Variation of EMI reduction across Temperature:	5% max. across $-40^{\circ}$ to $+85^{\circ}\text{C}$ w.r.t. room temperature
Modulation Carrier Frequency:	31.25kHz min, 62.50kHz max. (Frequency dependent: Table 1)
Frequency Stability***	
Commercial ( $0\sim 70^{\circ}\text{C}$ ):	$\pm 25\text{ppm}$ (Spec. code = 'A') $\pm 50\text{ppm}$ (Spec. code = 'B') $\pm 100\text{ppm}$ (Spec. code = 'C')
Industrial ( $-40\sim +85^{\circ}\text{C}$ ):	$\pm 25\text{ppm}$ (Spec. code = 'D') $\pm 50\text{ppm}$ (Spec. code = 'E') $\pm 100\text{ppm}$ (Spec. code = 'F')
Rise/Fall Times:	5ns max, (10% to 90% Vdd)
Start-up Time:	5ms typical, 10ms max.
Stabilisation (PLL Lock) Time:	2ms maximum.
Ageing:	$\pm 5\text{ppm}/\text{year}$
Output Logic:	CMOS Square Wave
Input Voltage:	+3.3Volts DC $\pm 10\%$
Output Voltage HIGH '1':	2.4V min., IOH = -4mA at Spread Spectrum output
Output Voltage LOW '0':	0.4V max., IOH = 4mA at Spread Spectrum output
Load:	15pF maximum
Current Consumption (no load)	
12MHz:	28mA
24MHz:	33mA
32MHz:	41mA
Duty Cycle:	$50\% \pm 10\%$ (CL=15pF, 50%Vdd)
Cycle to Cycle Jitter:	See table 2
Output Impedance:	45 to 90 $\Omega$ typical. Dependent upon output frequency spread type and spread magnitude
Packaging:	EIA 16mm tape and reel, 1k per.
Pad 1 Function:	No connection

### CYCLE-TO-CYCLE JITTER Table 2

8.0MHz:	240ps typical, 450ps maximum
16.0MHz:	270ps typical, 400ps maximum
32.0MHz:	240ps typical, 380ps maximum
64.0MHz:	165ps typical, 380ps maximum
128.0MHz:	150ps typical, 380ps maximum

### OUTLINE & DIMENSIONS

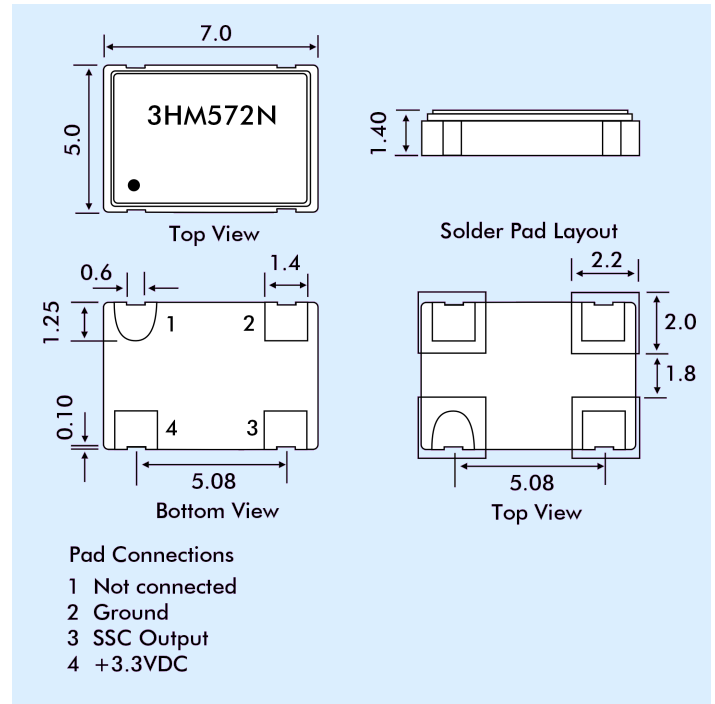

### SSC BLOCK DIAGRAM

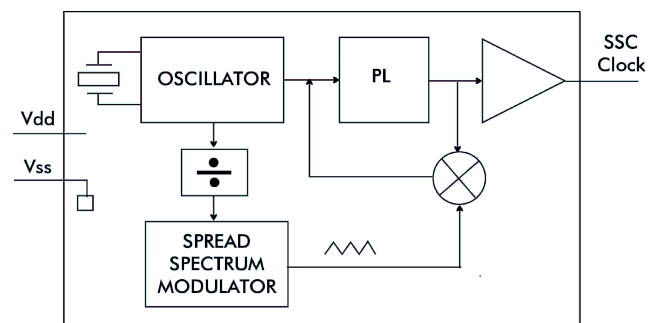

SPREAD TYPE & MODULATION MAGNITUDE Table 1

Frequency Range (MHz)	Modulation Carrier Frequency (kHz)	Spread Type and Modulation Magnitude (%) (Spread Spectrum Part Code)			
		Centre Spread ('C')		Down Spread ('D')	
fo					
8.0 ~ 9.99	fo/256	±1.4% (C1.4)	±0.6% (C0.6)	-3.0% (D3)	-2.2% (D2.2)
10.0 ~ 11.99		±1.3% (C1.3)	±0.5% (C0.5)	-2.7% (D2.7)	-1.9% (D1.9)
12.0 ~ 13.99		±1.2% (C1.2)	±0.5% (C0.5)	-2.5% (D2.5)	-1.8% (D1.8)
14.0 ~ 15.99		±1.1% (C1.1)	±0.4% (C0.4)	-2.3% (D2.3)	-1.7% (D1.7)
16.0 ~ 19.99	fo/512	±1.4% (C1.4)	±0.6% (C0.6)	-3.0% (D3)	-2.2% (D2.2)
20.0 ~ 23.99		±1.3% (C1.3)	±0.5% (C0.5)	-2.7% (D2.7)	-1.9% (D1.9)
24.0 ~ 27.99		±1.2% (C1.2)	±0.5% (C0.5)	-2.5% (D2.5)	-1.8% (D1.8)
28.0 ~ 31.99		±1.1% (C1.1)	±0.4% (C0.4)	-2.3% (D2.3)	-1.7% (D1.7)
32.0 ~ 39.99	fo/256	±1.4% (C1.4)	±0.6% (C0.6)	-3.0% (D3)	-2.2% (D2.2)
40.0 ~ 47.99		±1.3% (C1.3)	±0.5% (C0.5)	-2.7% (D2.7)	-1.9% (D1.9)
48.0 ~ 55.99		±1.2% (C1.2)	±0.5% (C0.5)	-2.5% (D2.5)	-1.8% (D1.8)
56.0 ~ 63.99		±1.1% (C1.1)	±0.4% (C0.4)	-2.3% (D2.3)	-1.7% (D1.7)
64.0 ~ 79.99	fo/512	±1.4% (C1.4)	±0.6% (C0.6)	-3.0% (D3)	-2.2% (D2.2)
80.0 ~ 95.99		±1.3% (C1.3)	±0.5% (C0.5)	-2.7% (D2.7)	-1.9% (D1.9)
96.0 ~ 111.99		±1.2% (C1.2)	±0.5% (C0.5)	-2.5% (D2.5)	-1.8% (D1.8)
112.0 ~ 128.0		±1.1% (C1.1)	±0.4% (C0.4)	-2.3% (D2.3)	-1.7% (D1.7)

### ENVIRONMENTAL SPECIFICATION

RoHS Compliance:	RoHS compliant and Pb (lead) free in accordance with EU Directive 2002/95/EC 6/6 (2002/95/EC) and WEEE (2002/96/EC)
Moisture Sensitivity Level:	Level 1 (infinite) according to IPC/JEDEC J-STD-020D.1
Second Level Interconnect:	e4
Humidity:	85% RH, 85°C for 48 hours
Fine Leak / Gross Leak:	MIL-STD-883, method 1014, condition A / MIL-STD-883, method 1014, condition C
Solderability:	MIL-STD-2002F method 208E
Reflow:	260° for 10 seconds 2 times
Vibration:	MIL-STD-202F method 204, 35G 50 to 2000Hz
Shock:	MIL-STD-202F method 213B, test condition: E, 1000g 1/2 sine wave
Resistance to Solvents:	MIL-STD-202, method 215
Temperature Cycling:	MIL-STD-883, method 1010
ESD Rating:	2kV minimum per JEDEC STD 22-A114-B
Pad Surface Finish:	Gold (Au) (0.3µm minimum) over Nickel (Ni) (1.27µm to 8.89µm)
Device Mass (Weight):	0.14mg per unit typical

### PART NUMBER FORMAT AND EXAMPLE

