

Miniature SMD Crystal for Series Oscillators 18kHz to 600kHz

FEATURES

- Frequency Range 18kHz to 600kHz
- High shock resistance
- Low ageing
- Designed for low power applications
- Full MIL testing available

DESCRIPTION

CX3HSM crystals consist of a high quality tuning fork resonator in a rugged, hermetically sealed ceramic package. CX3HSM crystals are intended for use in Series (two cascaded inverters) oscillator circuits.

SPECIFICATION

Specifications stated are typical at 25°C unless otherwise indicated. Specifications may change without notice.

Frequency Range:	18.0kHz to 600.0kHz
Standard Calibration Tolerance ¹ :	see table
Motional Resistance (R1):	Figure 1 Max = 18~25kHz, 2 x typical 25~600kHz, 2.5x typical
Motional Capacitance (C1):	Figure 2
Quality Factor (Q):	Figure 3 Min. is 0.25x typical
Shunt Capacitance (C0):	1.8pF max.
Drive Level	
18~24.9kHz:	1.5μW max.
25~600.0kHz:	3.0μW max.
Turning Point (T0) ² :	Figure 4
Temperature Coefficient (k):	-0.035ppm/°C ²
Ageing, first year:	5ppm max.
Shock, survival ³ :	1,500g, 0.3ms, ½ sine
Vibration, survival ³ :	10g rms, 20~2000Hz
Operating Temperature Range	
Commercial:	-10° to +70°C
Industrial:	-40° to +85°C
Military:	-55 to +125°C
Storage Temperature Range:	-55° to +125°C
Maximum Process Temperature:	+260°C for 20 seconds

1. Tighter frequency calibration is available.
2. Other turning point is available
3. Higher shock and vibration survival is available

PACKAGING OPTIONS

CX3HSM crystals are available either tray packed (<250pcs) or tape and reel (>250 pieces).
16mm tape, 178mm or 330mm reels (EIA 418).

HOW TO ORDER CX3HSM CRYSTALS

CX3H - S - C - SM1 - 32.0K, 30 / I

'S' if special, custom design. Otherwise leave blank

Blank = glass lid
C = ceramic lid

Terminations
SM1 = Gold plated *
SM2 = Solder plated
SM3 = Solder dipped
SM4 = Solder plated *
SM5 = Solder dipped *
* = Lead free

Frequency
K = kHz

Calibration Tolerance
@25°C
(in ppm)

Temp. Range
C = -10° ~ +70°C
I = -40° ~ +85°C
M = -55° ~ +125°C
S = Customer specified



OUTLINE & DIMENSIONS

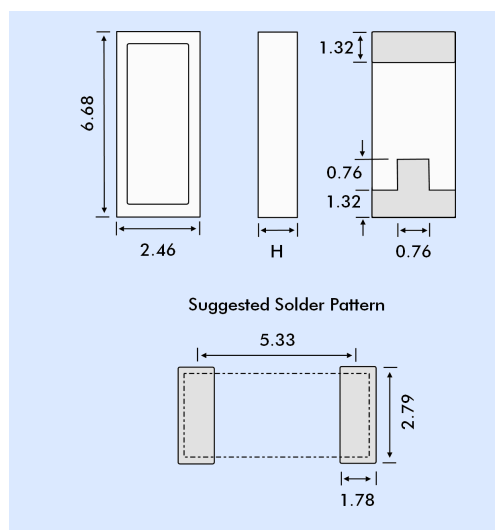

Dim. H	Glass Lid	Ceramic Lid
SM1	1.35	1.70
SM2	1.40	1.75
SM3	1.47	1.83
SM4	1.40	1.75
SM5	1.47	1.83

STANDARD CALIBRATION TOLERANCE

Frequency Range (kHz)			
18~74.9	75~169.9	170~249.9	250~600
±30ppm (0.003%)	±50ppm (0.005%)	±100ppm (0.01%)	±200ppm (0.02%)
±100ppm (0.01%)	±100ppm (0.01%)	±200ppm (0.02%)	±500ppm (0.05%)
±1000ppm (0.1%)	±1000ppm (0.1%)	±2000ppm (0.2%)	±5000ppm (0.5%)

CRYSTAL EQUIVALENT CIRCUIT

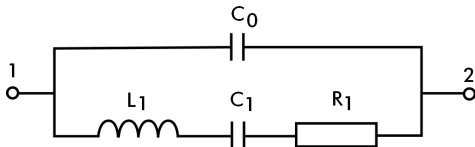

R1 Motional Resistance L1 Motional Inductance
 C1 Motional Capacitance C0 Shunt Capacitance

CONVENTIONAL SERIES OSCILLATOR CIRCUIT

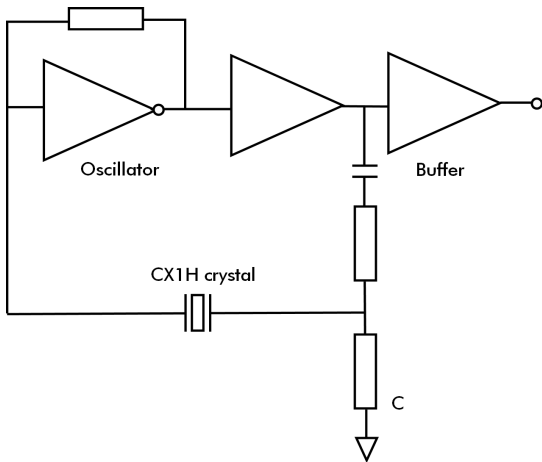

FIGURE 1
CX3H Typical Motional Resistance R1

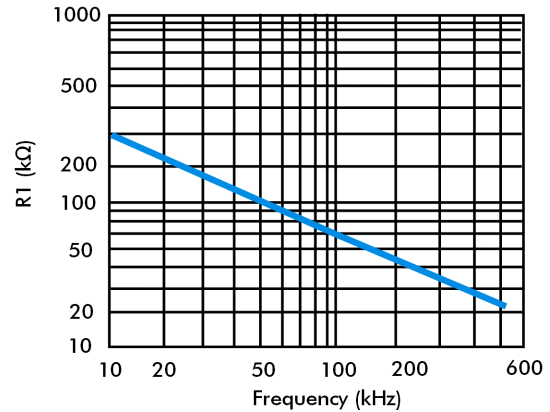

FIGURE 2
CX3H Typical Motional Capacitance C1

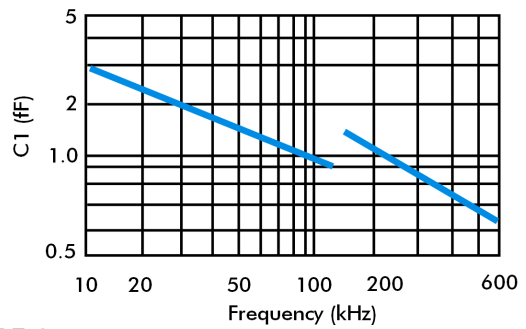

FIGURE 3
CX3H Typical Quality Factor (Q)

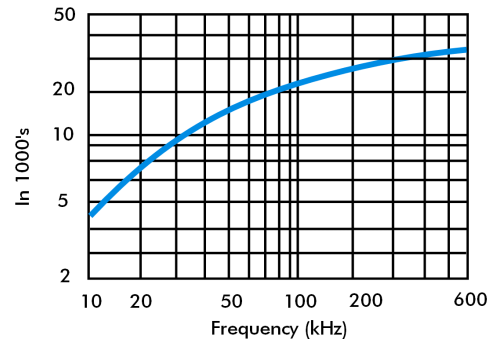
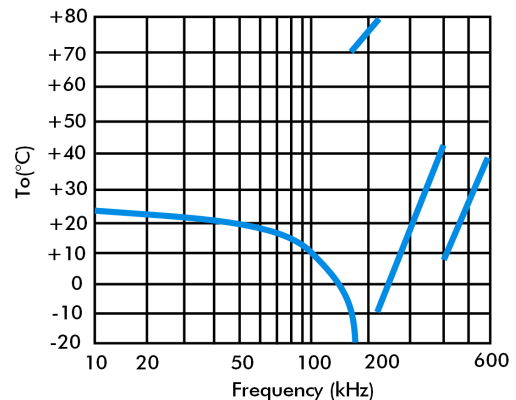

FIGURE 4
CX3H Typical Turning Point Temperature (To)



Turning Point Temperature

Note: Frequency f at temperature T is related to frequency F0 at turning point temperature To by:

$$\frac{f-f_0}{f_0} = k(T-T_0)^2$$