

## Miniature SMD Crystal for Pierce Oscillators 16kHz to 600kHz

### FEATURES

- Frequency Range 16kHz to 600kHz
- High shock resistance
- Low ageing
- Designed for low power applications
- Full MIL testing available

### DESCRIPTION

CX2VSM crystals are leadless devices designed for surface mounting on PCBs or hybrid substrates. The crystals are intended for use in Pierce (single inverter) oscillator circuits.

### SPECIFICATION

Specifications stated are typical at 25°C unless otherwise indicated. Specifications may change without notice.

|                                         |                                                                     |
|-----------------------------------------|---------------------------------------------------------------------|
| Frequency Range:                        | 16.0kHz to 600.0kHz                                                 |
| Functional Mode:                        | Tuning Fork (Flexure)                                               |
| Standard Calibration Tolerance*:        | see table                                                           |
| Motional Resistance (R <sub>1</sub> ):  | Figure 1<br>Max = 16~24.9kHz, 2x typical<br>25~600kHz, 2.5x typical |
| Motional Capacitance (C <sub>1</sub> ): | Figure 2                                                            |
| Quality Factor (Q):                     | Figure 3<br>Min. is 0.25x typical                                   |
| Shunt Capacitance (C <sub>0</sub> ):    | 2.0pF max.                                                          |
| Drive Level                             |                                                                     |
|                                         | 16~24.9kHz: 0.5μW max.                                              |
|                                         | 25~600.0kHz: 1.0μW max.                                             |
| Turning Point (T <sub>0</sub> )**:      | Figure 4                                                            |
| Temperature Coefficient (k):            | -0.035ppm/°C <sup>2</sup>                                           |
| Ageing, first year:                     | 5ppm max.                                                           |
| Shock, survival***:                     | 1,500g, 0.3ms, ½ sine                                               |
| Vibration, survival***:                 | 10g rms, 20~2000Hz                                                  |
| Operating Temperature Range             |                                                                     |
| Commercial:                             | -10° to +70°C                                                       |
| Industrial:                             | -40° to +85°C                                                       |
| Military:                               | -55 to +125°C                                                       |
| Storage Temperature Range:              | -55° to +125°C                                                      |
| Maximum Process Temperature:            | +260°C for 20 seconds                                               |

\* Tighter frequency calibration is available.

\*\* Other turning point is available

\*\*\* Higher shock and vibration survival is available

### PACKAGING OPTIONS

CX2VSM crystals are available either tray packed (<250pcs) or tape and reel (>250 pieces).

16mm tape, 178mm or 330mm reels (EIA 418).

### HOW TO ORDER CX2VSM CRYSTALS

**CX2V - S - C - SM1 - 32.768K 30 / I**

'S' if special, custom design. Otherwise leave blank

Blank = glass lid  
C = ceramic lid

Terminations  
SM1 = Gold plated \*  
SM2 = Solder plated  
SM3 = Solder dipped  
SM4 = Solder plated \*  
SM5 = Solder dipped \*  
\* = Lead free

Frequency  
K = kHz

Calibration  
Tolerance  
@25°C  
(in ppm)

Temp. Range  
C = -10° ~ +70°C  
I = -40° ~ +85°C  
M = -55° ~ +125°C  
S = Customer specified



### OUTLINE & DIMENSIONS

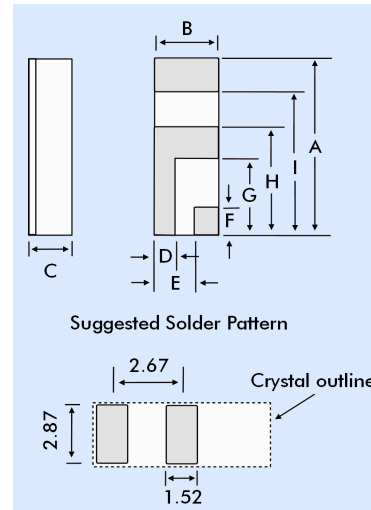

| Dim. | Typ.      | Max. |
|------|-----------|------|
| A    | 6.60      | 6.99 |
| B    | 2.39      | 2.74 |
| C    | see below |      |
| D    | 0.89      | 1.14 |
| E    | 1.50      | 1.75 |
| F    | 1.27      | 1.52 |
| G    | 2.67      | 2.92 |
| H    | 3.94      | 4.19 |
| I    | 5.33      | 5.59 |

| Dim. C | Glass Lid | Ceramic Lid |
|--------|-----------|-------------|
| SM1    | 1.65      | 1.91        |
| SM2    | 1.70      | 1.96        |
| SM3    | 1.78      | 2.03        |
| SM4    | 1.70      | 1.96        |
| SM5    | 1.78      | 2.03        |

### STANDARD CALIBRATION TOLERANCE

| Frequency Range (kHz) |                    |                    |                    |
|-----------------------|--------------------|--------------------|--------------------|
| 16~74.9               | 75~169.9           | 170~249            | 250~600            |
| ±30ppm<br>(0.003%)    | ±50ppm<br>(0.005%) | ±100ppm<br>(0.01%) | ±200ppm<br>(0.02%) |
| ±100ppm<br>(0.01%)    | ±100ppm<br>(0.01%) | ±200ppm<br>(0.02%) | ±500ppm<br>(0.05%) |
| ±1000ppm<br>(0.1%)    | ±1000ppm<br>(0.1%) | ±2000ppm<br>(0.2%) | ±5000ppm<br>(0.5%) |

### LOAD CAPACITANCE (CL)\*

| Frequency Range (kHz) | Load Capacitance | Frequency Range (kHz) | Load Capacitance |
|-----------------------|------------------|-----------------------|------------------|
| 16~24.9               | 10pF             | 100.0~179.9           | 5pF              |
| 25~54.9               | 9pF              | 180~600               | 4pF              |
| 55~100.0              | 8pF              |                       |                  |

\* The load capacitance we use to calibrate CX2VSM. (Other CL is available.)

**CRYSTAL EQUIVALENT CIRCUIT**

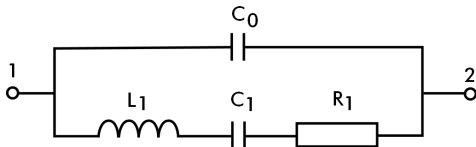

R1 Motional Resistance      L1 Motional Inductance  
 C1 Motional Capacitance    C0 Shunt Capacitance

**CONVENTIONAL CMOS PIERCE OSCILLATOR CIRCUIT**

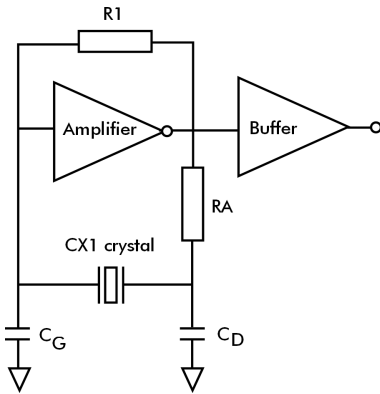

**TERMINATIONS - PLATING**

| Designation | Termination               |
|-------------|---------------------------|
| SM1         | Gold Plated (Lead Free)   |
| SM2         | Solder Plated             |
| SM3         | Solder Dipped             |
| SM4         | Solder Plated (Lead Free) |
| SM5         | Solder Dipped (Lead Free) |

**Turning Point Temperature**

Note: Frequency f at temperature T is related to frequency F0 at turning point temperature To by:

$$\frac{f-f_0}{f_0} = k(T-T_0)^2$$

**FIGURE 1  
 CX2V Typical Motional Resistance R1**

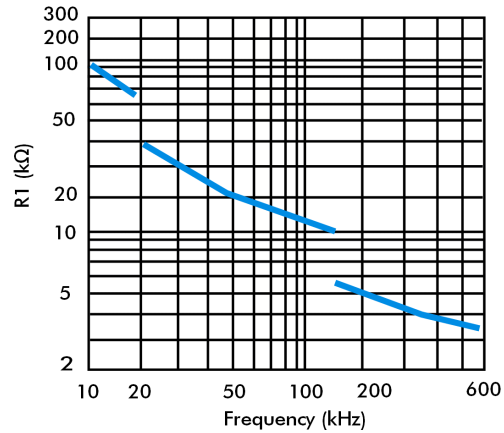

**FIGURE 2  
 CX2V Typical Motional Capacitance C1**

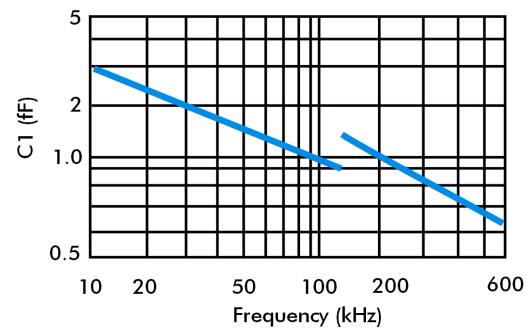

**FIGURE 3  
 CX2V Typical Quality Factor (Q)**

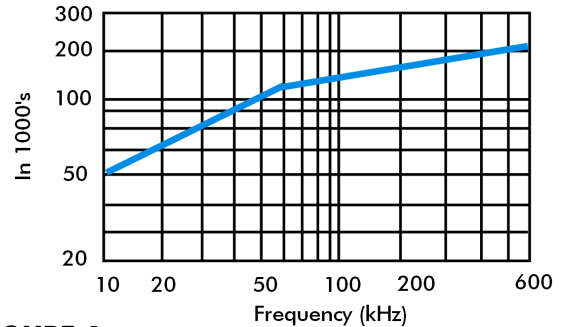

**FIGURE 4  
 CX2V Typical Turning Point Temperature (To)**

